

x x		

K

K



x fi

fi



E

K fi x

x K

K

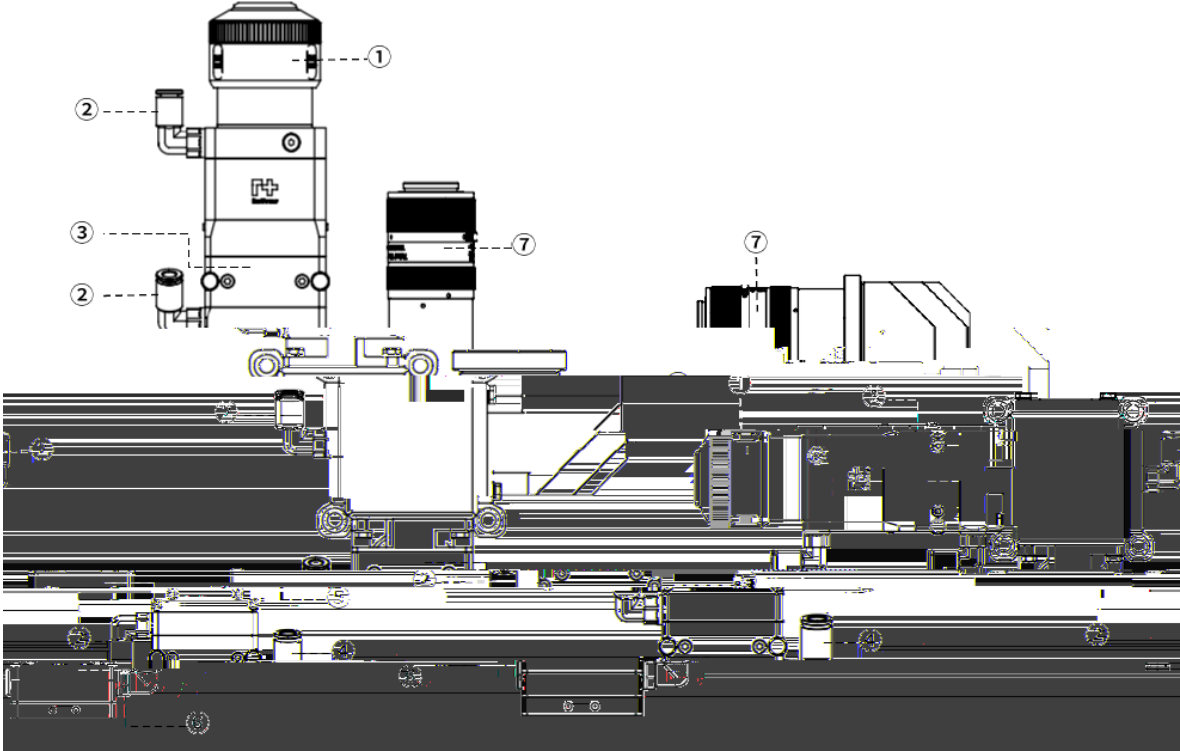

	∞

K

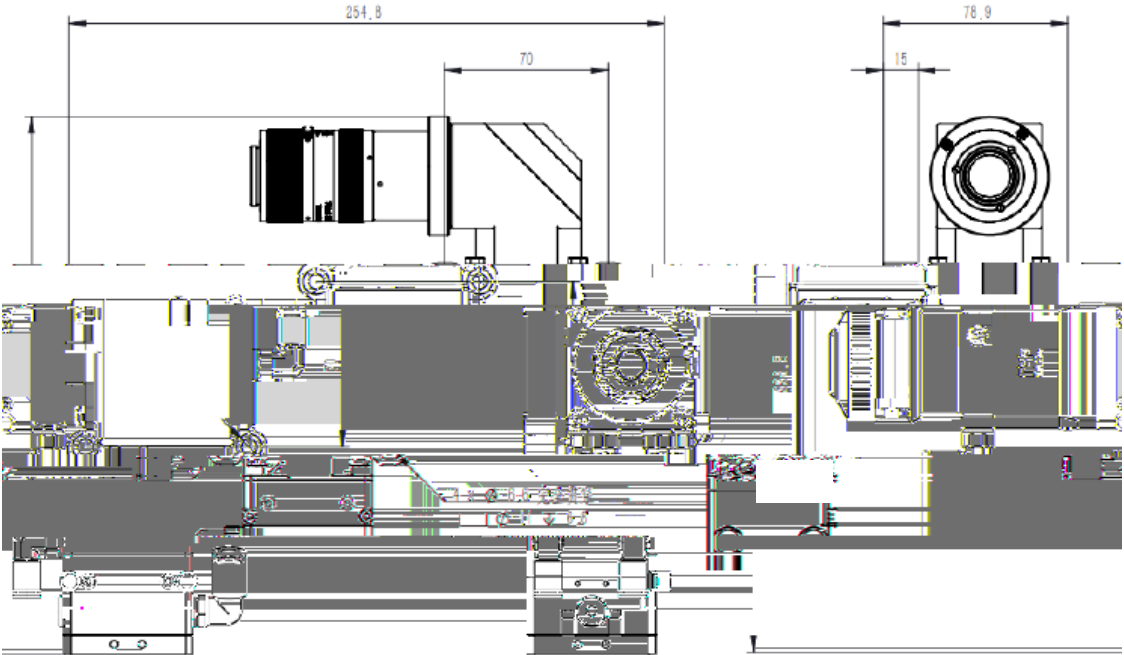
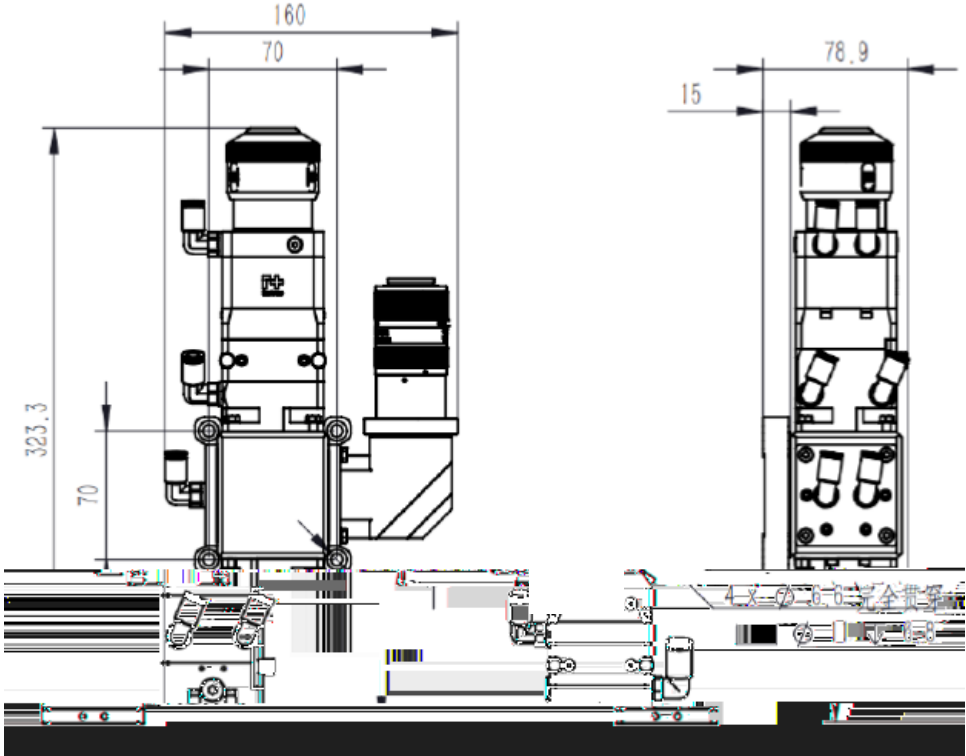

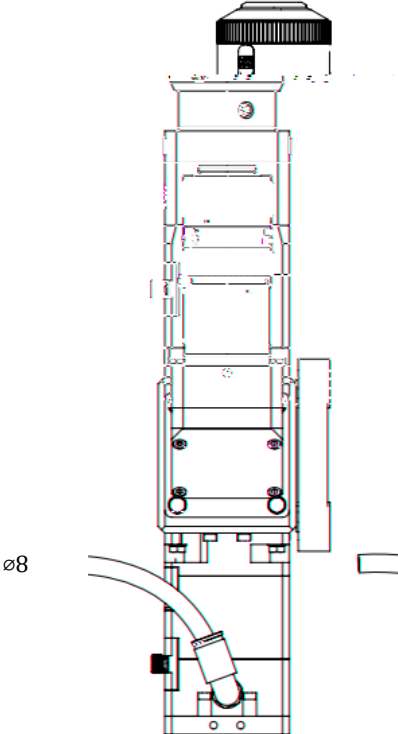

fi

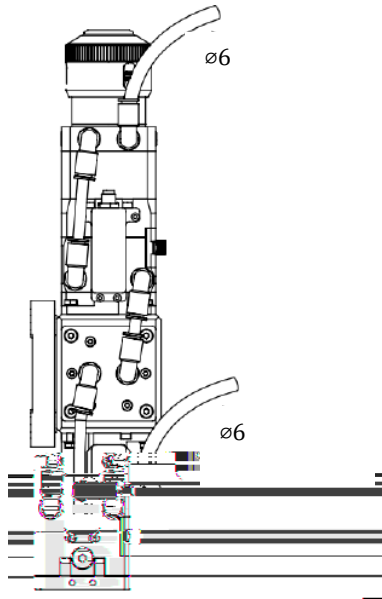

	Ø	
	°C °C	°C °C
	°C °C	°C °C
	≧	



fi

x

X

E

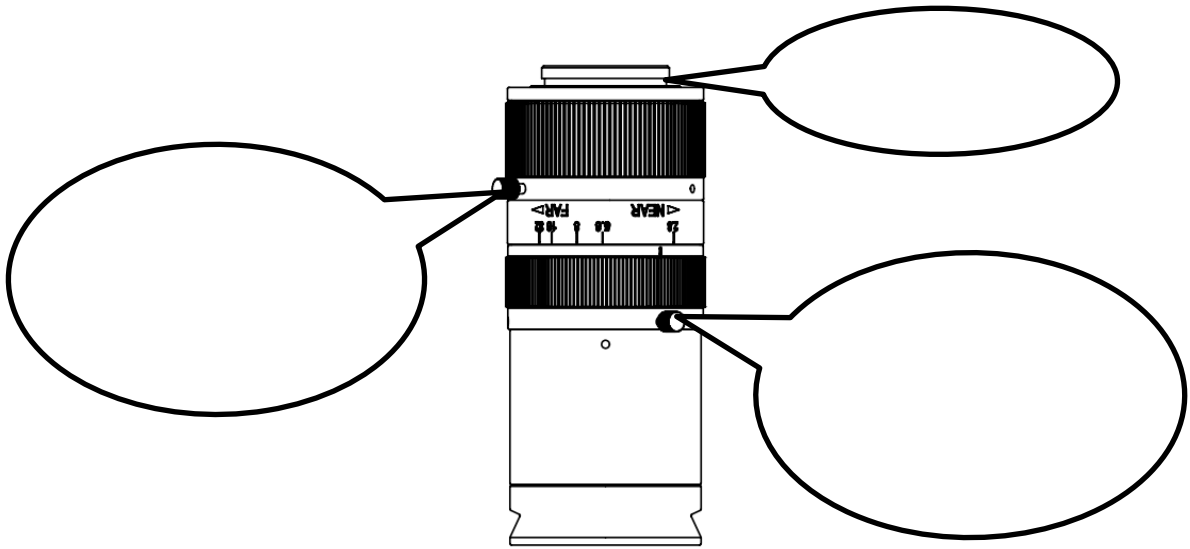

A

X

X

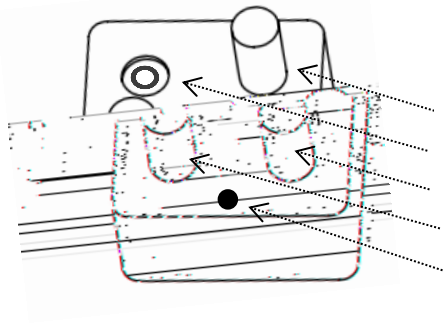
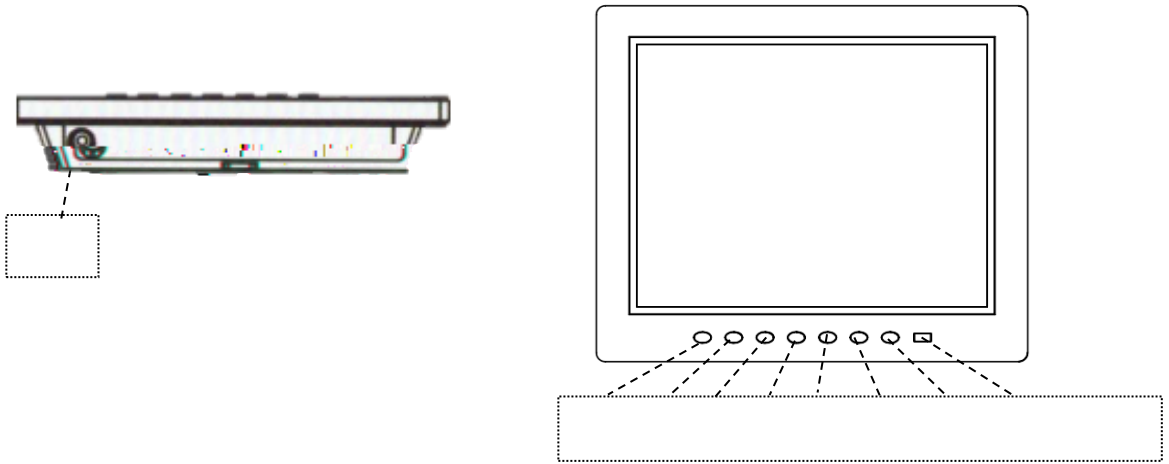

A x

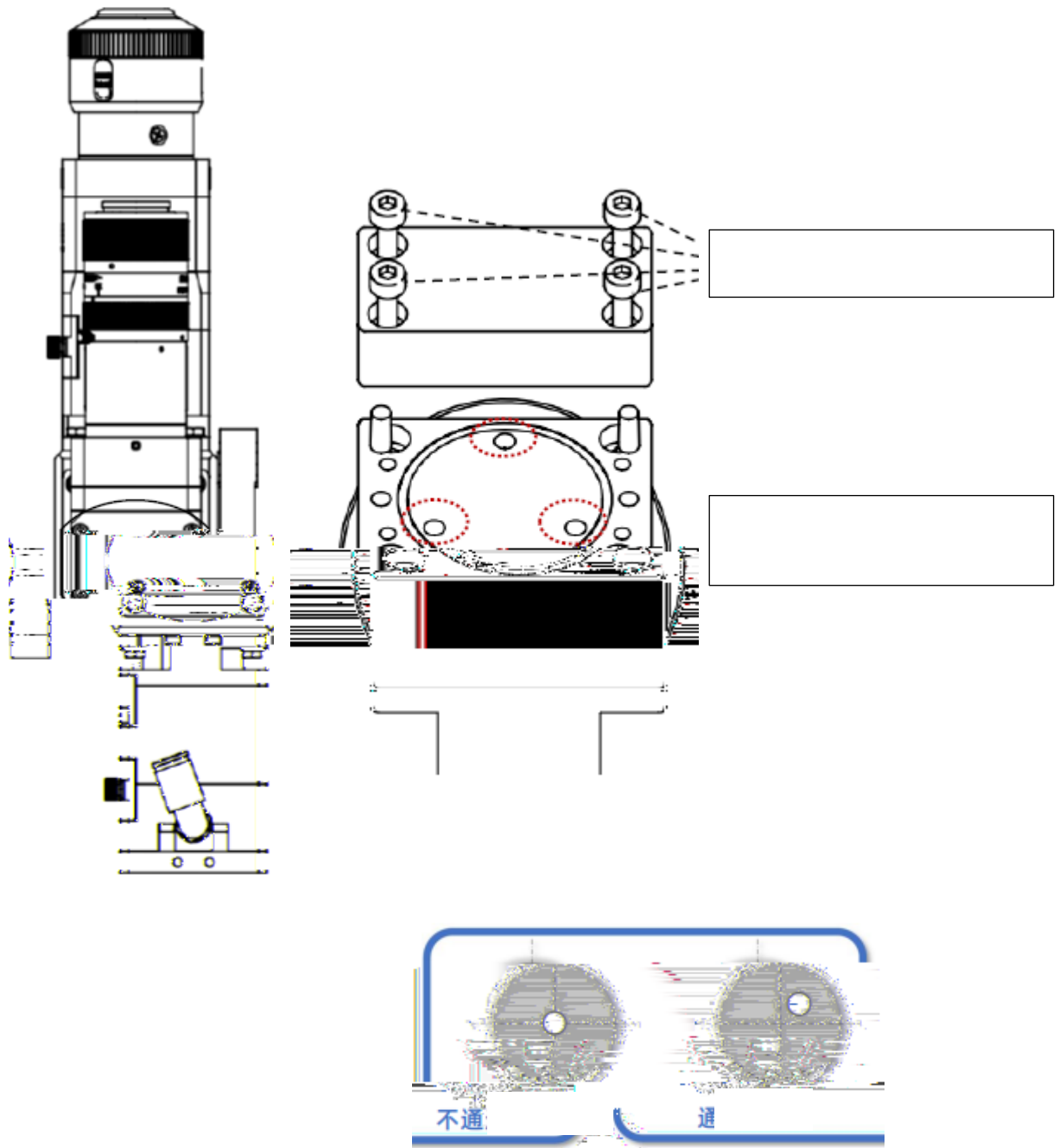

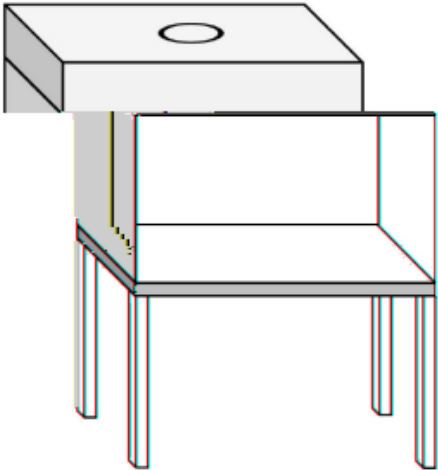

W

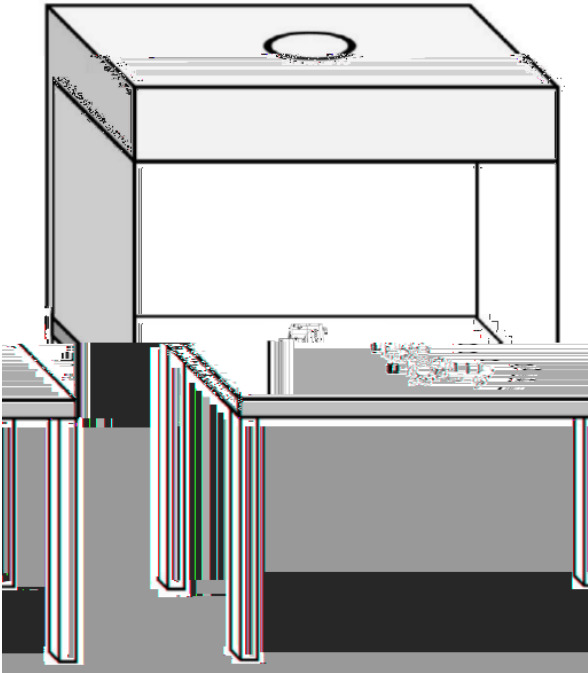

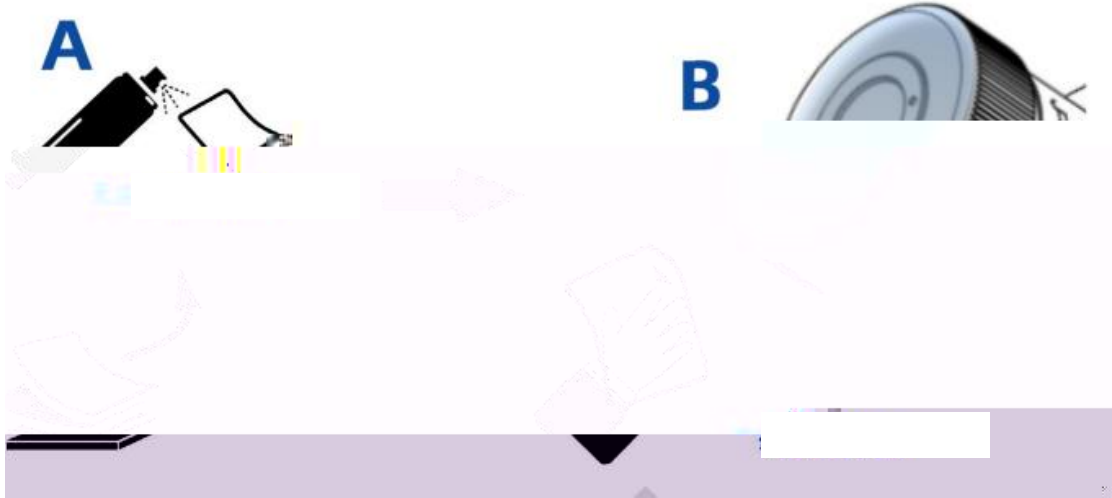

A

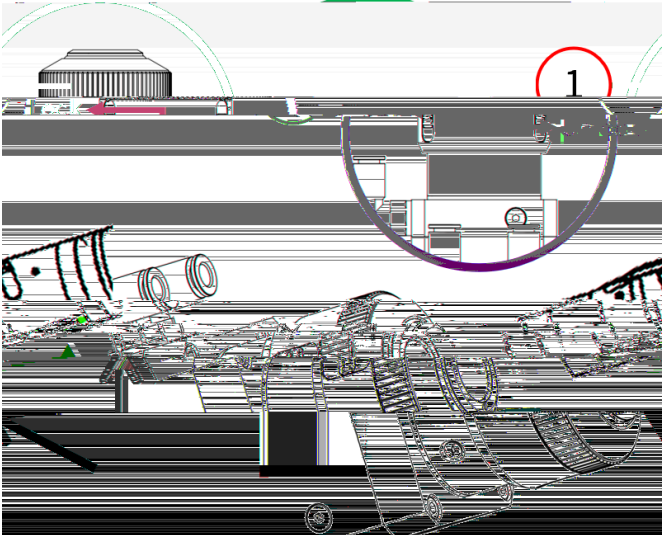

A

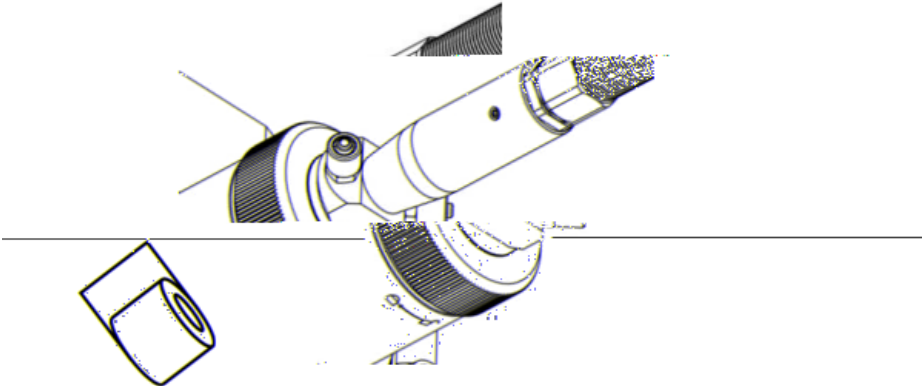

fi E x fi x

fi

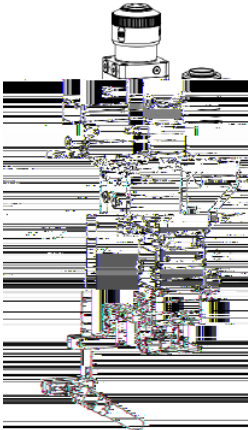
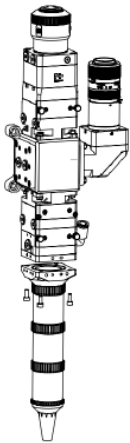
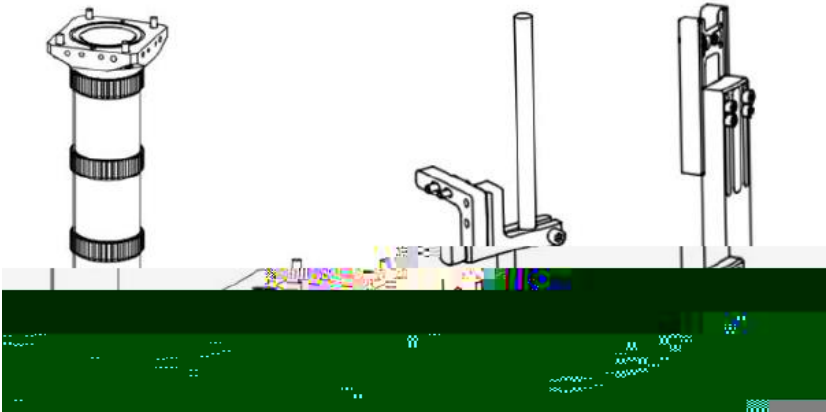

X

E

X

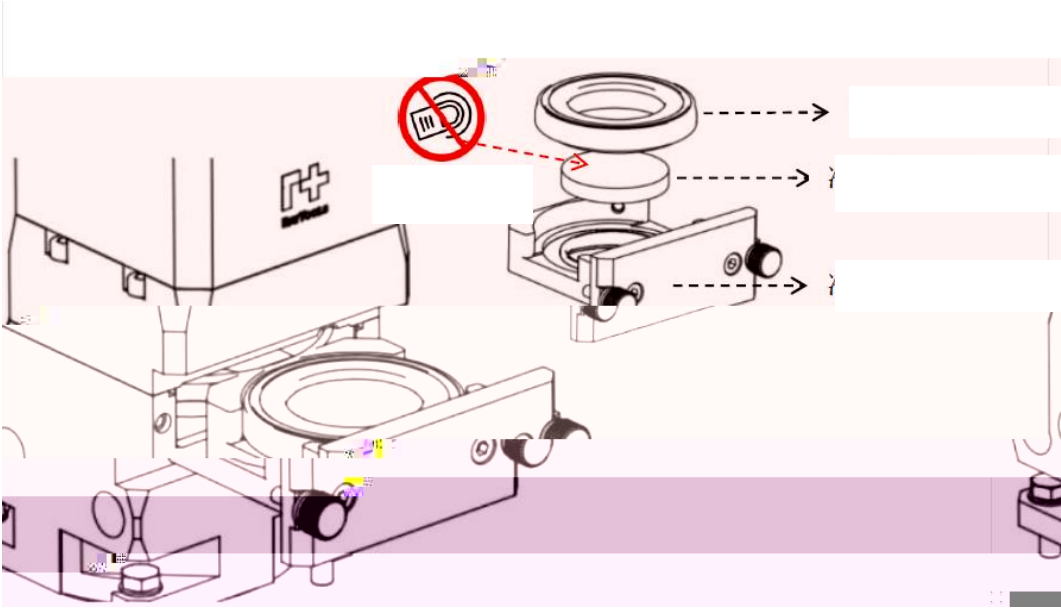

x

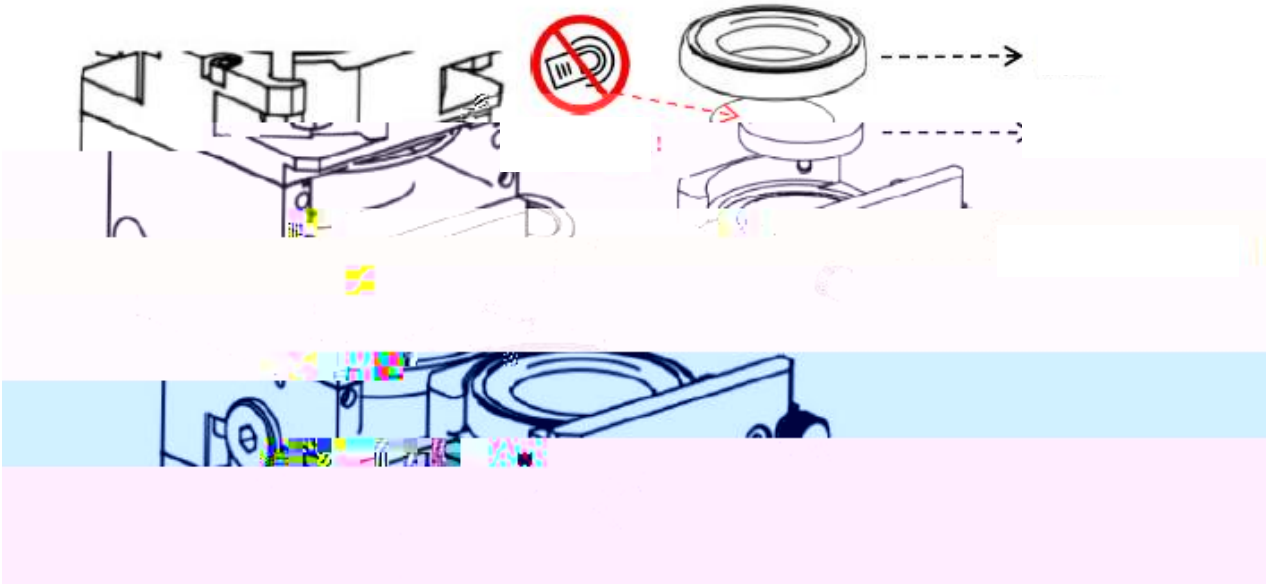

x

K

